

# IP55 Field Cabinet

# IP-453522-GRN

**STEEL | POLE MOUNT | IP55**

**450H x 350W x 225D**

**Pole-Mounted Field Cabinets** are designed to house sensitive data network and electrical equipment for a variety of heavy duty outdoor applications including general industrial, infrastructure, road/traffic management and intelligent transport systems.

**Protection:** Complies with IP55 (Ventilated)

**Standard:** IEC62208, IEC/EN/AS60529

**Material:**

- Body: 1.5mm galvanised steel sheet
- Doors: 2.0mm galvanised steel sheet
- Enclosure Seal: Polyurethane

**Body:** The robust monoblock body is fabricated using 1.5mm galvanised steel sheet. Precision automated manufacturing equipment ensures accuracy and consistent high quality. Flat face sealing surfaces increase seal life. Integral device plate mounts and M6 earth stud are included. Fan/filter cutouts and hinged vent hoods are provided as standard.

**Doors:** The front door is fabricated using 2.0mm galvanised steel sheet and is designed to provide flush recessed mounting to prevent vandalism and unauthorised access. The door incorporates concealed removable hinges with captive pins. It is hinged on the left side, designed for a 110° opening and is provided with a heavy duty door stay. An A4 plan pocket is provided.

**Seal:** A high quality machine-applied full perimeter UL listed Polyurethane seal foamed in place (FIP) provides excellent sealing over a long life. Temperature resistance -40°C to 80°C (160°C short term loading).

**Device Mounting Plate:** The device mounting plate is 1.5mm galvanised steel sheet. It is pressed to provide strength. It is pre-fitted into the enclosure as standard. Powder coated RAL9010 pure white.

**Locks:** 3 point locking systems with key-lock swing handles.

**Surface Treatment:** UL approved epoxy polyester powder-coated with a textured finish. 80-120 micron average thickness. RAL6005 Moss Green.

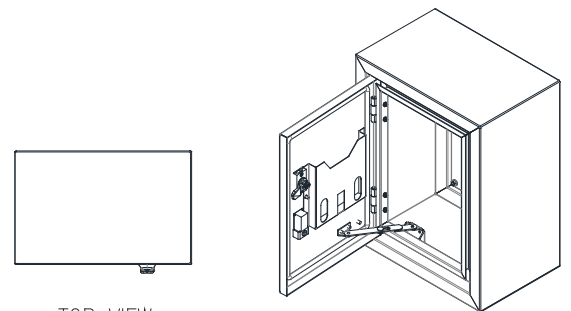

TOP VIEW

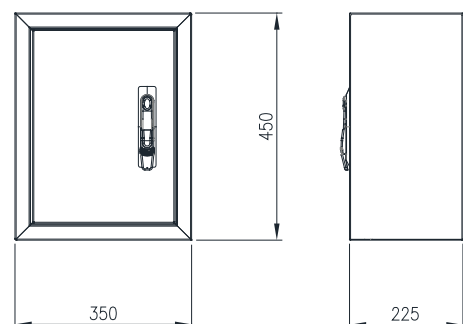

FRONT VIEW

SIDE VIEW